

# PHILIPS



**AQ 6526**

GB	Stereo radio cassette player	4
F	Radio lecteur de cassettes stéréo	8
D	Stereo Radio-Cassettenspieler	8
NL	Stereo radio-cassettespeler	10
E	Radio-tocasetes esteréo	12
I	Radio-lettore cassette stereo	14
S	Stereo Radio-kassettspelare	16
SF	Stereo radiokassettsortin	18



**PHILIPS**

### **Declaración de conformidad con normas**

El que suscribe, en nombre y representación de:  
**ACTEAM Hong Kong, Division of Philips China  
Hong Kong Group Company Limited**

Declara, bajo su propia responsabilidad, que el  
equipo: **Radio tocasetes estéreo**

fabricado por: **ACTEAM Hong Kong**

en: **Far East**

marca: **Philips**

modelos: **AQ 6526**

Objeto de esta declaración, cumple con la normativa  
siguiente: Reglamento sobre Perturbaciones  
Radioeléctricas, Real Decreto 138/1989, Anexo  
V. Hecho en: Hong Kong, 13-04-1992

Firma:



Nombre: **C.S. Lau**

Función: **Quality Assurance Manager**

**English.....4**

Illustrations .....20

GB

**Français.....6**

Illustrations .....20

F

**Deutsch.....8**

Abbildungen.....20

D

**Nederlands.....10**

Afbeeldingen.....20

NL

**Español.....12**

Ilustraciones .....20

E

**Italiano.....14**

Illustrazioni .....20

I

**Svenska.....16**

Figurer .....20

S

**Suomi.....18**

Kuvat .....20

SF

# Radio

## SUPPLY

---

GB

### Batteries

Insert as indicated two alkaline batteries, type R6, UM3 or AA. Remove the batteries if exhausted or if they are not to be used for a long time.

### Mains adapter

Connect a mains adapter to the 3V DC socket. The adapter must supply 3V DC  $\oplus$   $\ominus$ , minuspole  $\ominus$  to the 1.3 mm centre pin of the 3.4 mm socket.

## RADIO RECEPTION

---

- Set **TAPE/RADIO** to **RADIO**.
- Connect headphones to **PHONES**.
- Set **AM/FM/FM ST** to **AM (=MW)**, **FM (mono)** or to **FM ST (stereo)**.
- Tune to the desired radio station using **TUNING**. The headphone lead will function as FM-aerial.
- Adjust the sound with **VOLUME** and **DBB (bass)**.
- If **AM/FM/FM ST** is in position **FM ST**, you will hear FM stereo programmes in stereo. The **FM ST \*** indicator will light up then. The disturbing noise due to a weak FM stereo signal can be suppressed by setting **AM/FM/FM ST** to **FM (mono)**. The **FM ST \*** indicator then goes out and you hear the programme in mono.
- The set is switched off when **TAPE/RADIO** is in position **TAPE** and no cassette player button is pressed.

# Cassette Player

## PLAYING BACK CASSETTES

---

GB

- Set **TAPE/RADIO** to **TAPE**.
- Connect headphones to  $\Omega$ .
- Open the cassette holder and insert the cassette in it with the open part facing the buttons.
- Set the **METAL-CrO<sub>2</sub> / NORMAL** selector to:
  - **METAL-CrO<sub>2</sub>** for METAL (IEC VI) or CHROME (IEC II) cassettes
  - **NORMAL** for NORMAL (IEC I) cassettes
- Adjust **DOLBY NR**  $\square\square$  (noise reduction) **ON** or **OFF**.
- To start playback, press  $\blacktriangleleft$ .
- Adjust the sound with **VOLUME** and **DBB (bass)**.
- To stop, press **STOP** and the set is switched off.
- At the end of the tape the  $\blacktriangleleft$  button is automatically released and the set is switched off.
- **Fast Winding:** Press  $\blacktriangleleft$  or  $\blacktriangleright$ . Press **STOP** to stop fast winding and also when the tape has reached it's end.

## MAINTENANCE

---

- Clean the magnetic head after every 50 hours of operation or, on average, once a month by playing through a cleaning cassette.
- Do not expose the set and cassettes to rain, moisture, sand, or to excessive heat from e.g. heating equipment or in motor cars parked in the sun.

*The type number will be found at the bottom of the set and the serial number in the battery compartment.*

*This set complies with the radio interference requirements of the European Community.*

Dolby noise reduction manufactured under license from Dolby Laboratories Licensing Corporation. Dolby and the double-D symbol  $\square\square$  are trademarks of Dolby Laboratories Licensing Corporation.

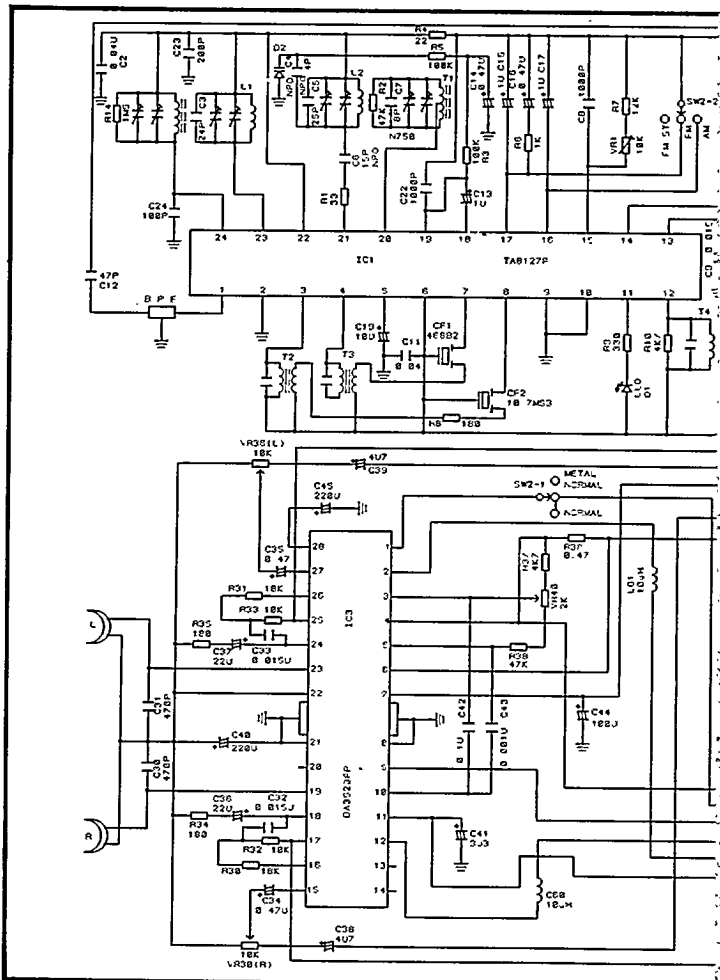



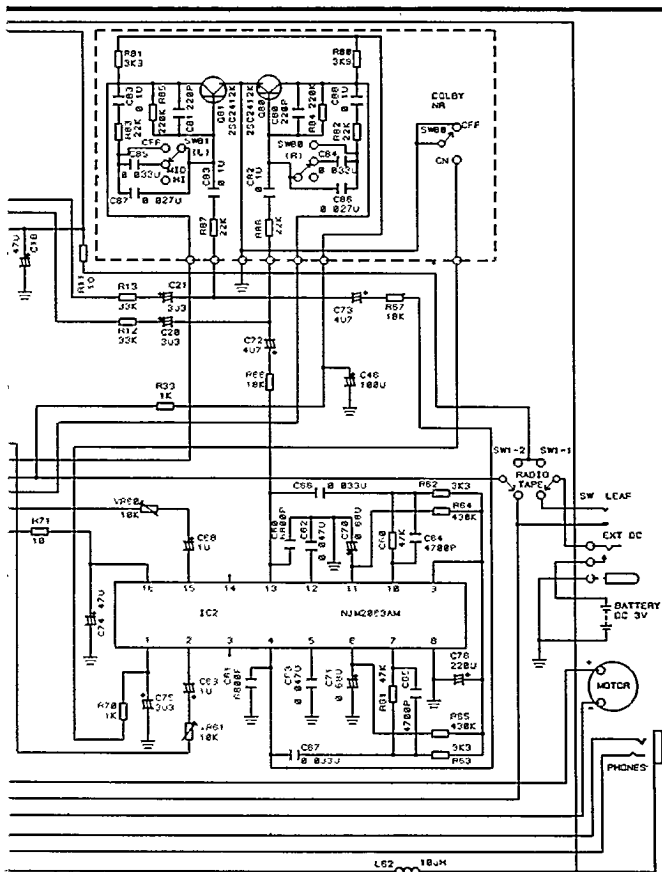

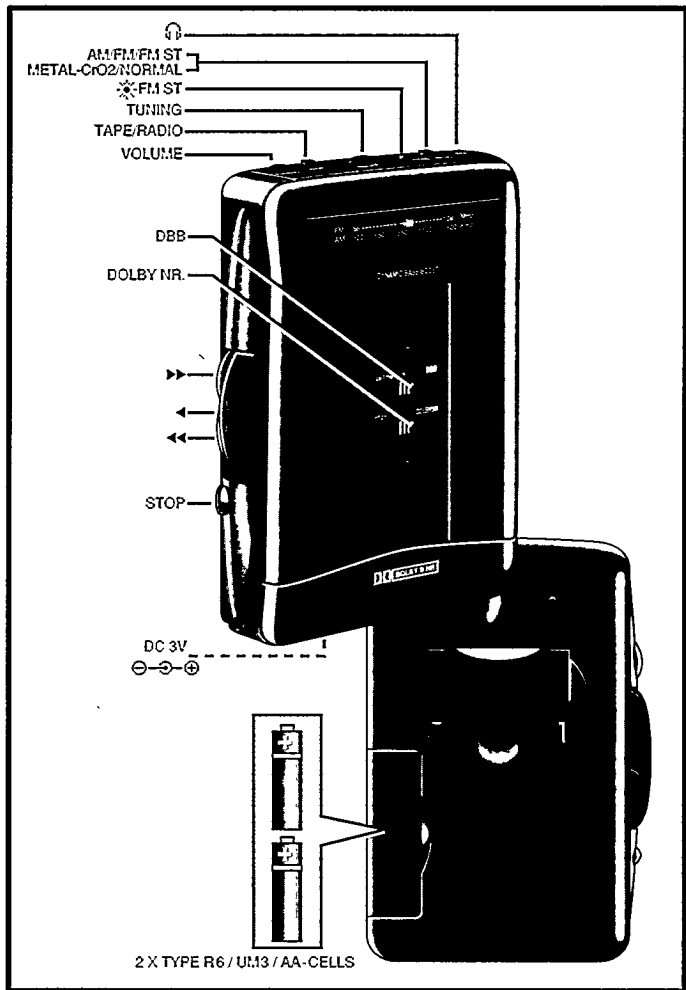

## **GARANTEE AND SERVICE VALID FOR AUSTRALIA**

The benefits given to the purchaser by this warranty are in addition to all other rights and remedies, which, under the Trade Practices Act or other Commonwealth or State law, the purchaser or owner has in respect of the product. The Philips product carries the following warranties: C-series HiFi systems 12 months, Compact Disc Players 12 months, Home Audio Systems 6 months, Clock radios, portable radios, cassette recorders, cassette players and radio recorders 90 days.

Any defect in materials or workmanship occurring within the specified period from the date of delivery, will be rectified free of charge by the retailer from whom this product was purchased.

*Note:* Please retain your purchase docket to assist prompt service.

### **Conditions of this warranty**

1. All claims for warranty service must be made to the retailer from whom this product was purchased. All transport charges incurred in connection with warranty service or replacement will be paid by the purchaser.
2. These warranties do not cover batteries and extend only to defects in materials or workmanship occurring under normal use of the product where operated in accordance with our instructions.

**Philips Consumer Products Division, Technology Park, Figtree Drive, Australia Centre,  
HOMEBUSH 2140, New South Wales**

## **GARANTEE AND SERVICE FOR NEW ZEALAND**

Thank you for purchasing this quality Philips product. The document you are now reading is your guarantee card **Guarantee.**

Philips New Zealand Ltd guarantees this product against defective components and faulty workmanship for a period of 12 months. Any defect in materials or workmanship occurring within 12 months from the date of purchase subject to the following conditions will be rectified free of charge by the retailer from whom this product was purchased.

### **Conditions.**

1. The product must have been purchased in New Zealand, and this guarantee card completed at time of purchase (this is your proof of date of purchase).
2. The guarantee applies only to faults caused by defective components, or faulty workmanship on the part of the manufacturer.
3. The guarantee does not cover failures caused by misuse, neglect, normal wear and tear, accidental breakage, use on the incorrect voltage, use contrary to operating instructions, or unauthorised modification to the product or repair by an unauthorised technician.
4. Reasonable evidence (in the form of a sales docket or completed guarantee card) must be supplied to indicate that the product was purchased no more than 12 months prior to the date of your claim.
5. In the event of a failure, Philips shall be under no liability for any injury, or any loss or damage caused to property or products other than the product under guarantee.

*This guarantee does not prejudice your rights under common law and statute, and is in addition to the normal responsibilities of the retailer and Philips.*

**How to claim:** Should your Philips product fail within the guarantee period, please return it to the retailer from whom it was purchased. In most cases the retailer will be able to satisfactorily repair or replace the product. However, should the retailer not be able to conclude the matter satisfactorily, or if you have other difficulties claiming under this guarantee, please contact:

**The Guarantee Controller, Philips New Zealand Ltd, P.O. Box 1041, AUCKLAND - (09) 605-914**

## **GARANTÍA PARA MÉXICO**

Este aparato está fabricado con materiales de alta calidad y ha sido cuidadosamente verificado. Philips, por lo tanto, da a usted una garantía de 12 meses a partir de su fecha de compra.

La garantía ampara la reparación de las piezas defectuosas debidas a fallas en su montaje o en los materiales, incluyendo la mano de obra necesaria para su reemplazo en nuestras Sucursales o talleres autorizados.

En caso de fallas en su aparato le rogamos se sirva poner en contacto con su distribuidor.

Esta garantía no cubrirá las avarias que resulten como consecuencia de una instalación incorrecta del aparato, maltrato, maltrato o uso inadecuado del mismo.

Philips se obliga a reparar y devolver a usted su aparato en un plazo no mayor de 30 días hábiles contados a partir de la fecha de haber ingresado su aparato a uno de nuestros talleres.

Para que esta garantía sea válida, es necesario que el certificado que figura en la parte posterior de este instructivo haya sido debidamente llenado en el momento de la compra del aparato.

En caso de extravío del certificado con la presentación de la factura o remisión de su aparato podrá hacer efectiva la garantía correspondiente.

Si usted tiene alguna duda o pregunta que no le pueda solucionar su distribuidor, por favor ponerse en contacto con:

**Oficinas Centrales de Servicio, Av. Coyoacán No. 1051, Col. del Valle,**

**03100 MEXICO, D.F. - (5-75-20-22 o 5-75-01-00)**



- (GB) This sign on the packaging is only meant for Germany
- (F) Ce signal sur l'emballage concerne uniquement l'Allemagne
- (D) Dieses Zeichen auf der Verpackung gilt nur für Deutschland
- (NL) Dit teken op de verpakking geldt alleen voor Duitsland
- (E) Este símbolo en el embalaje es únicamente para Alemania
- (I) Questo contrassegno sull'imballaggio interessa solo la Germania
- (P) Este símbolo na embalagem é só para a Alemanha
- (DK) Dette mærke har kun betydning i Tyskland
- (S) Recirkulationsmärket på förpackningen avser endast för Tyskland
- (SF) Tämä merkki pakkauksessa koskee vain Saksaa



8204 000 5373 2

Printed in Hong Kong